

### 3CCD Multiple-Purpose HDTV camera

# HDL-F25i



The HDL-F25i is a Multi-purpose Compact HDTV camera equipped with high resolution 2.2 million pixel IT CCDs, provides superb color reproduction with the latest full digital process ASIC and 14-bit A/D converters, and is suitable for various applications such as helicopter camera, weather camera, jib arm camera and more....

#### ■ Minimized 80mm (3.15 inches) depth of camera head

Minimized depth of the camera head permits installation with telephoto lens into the limited space of a small gimbal. Mechanical design of the rear panel without protrusions makes cable wiring easier in a limited space.

#### ■ Compact and light weight CCU

Compact size and flat bottom of the CCU allows easy installation, even for small helicopters. Space conscious design with all connectors located on one side minimizes installation space with easier wiring.

#### ■ 2.2M pixel full HD IT CCDs

Three 1920x1080 pixel CCDs provide 1000TVL resolution, F9 sensitivity and 56dB SNR.

#### ■ The latest 14-bit A/D Converters

14-bit A/D converters provide precise picture images from blacks to high lights, especially maximizing the color gradation for dark areas, and achieving natural color reproduction.

#### ■ Built-in Filter Servo / ECC (Electronic Color Compensation) filter

The 4-position optical filter wheel can be remotely controlled from a remote control panel. Adopting ECC filter (3200K/5600K) gives proper white balance without reducing sensitivity, a benefit under high color temperature but low light conditions such as dawn and dusk. The ND filter and ECC filter can be independently controlled.

#### ■ Lower noise gain up

The HDL-F25i employs low-noise feed-back type amplifier circuits for Master gain up, as well as, noise cancelling circuits in all video related boards, eliminating noticeable noise, and obtaining a better signal-to-noise with high gain up.

#### ■ 2 channel HD-SDI output

Two HD-SDI outputs are available. Each channel can be individually set for menu display On/Off and monitor output with markers, etc. One output can be used for PGM and another for MON so that menu control is available even during live production.

# 3CCD Multiple-Purpose HDTV camera HDL-F25i

## Rating:

Scanning System	1080i (59.94Hz or 50Hz)
Image Sensor	2/3-inch, 2.2million pixel, IT CCD
Effective Number of Pixels	1920(H) x 1080(V)
Sensitivity	F9 at 2000lx, White reflection 89.9%
Optical System	2/3-inch, RGB 3CCD, F1.4
Lens Mount	BTA S-1005B
Optical Filter	(Pos.) 1 2 3 4
(w/Filter Servo)	(ND) 100% 25% 6.2% 1.6%
ECC	3200K / 5600K Selectable
Sampling Frequency	74.1758MHz or 74.25MHz
Quantization	14-bit
Power Requirement	+11VDC~ +16VDC(Up to 15m Camera Cable) +12VDC~ +16VDC(Up to 50m Camera Cable)

## Operating Temperature

Camera Head	-20 °C~ +45 °C / -4 °F~ 113 °F
CCU	-10 °C~ +45 °C / 14 °F~ 113 °F

## Storage Temperature

Camera Head	-30 °C~ +60 °C / -22 °F~ 140 °F
CCU	-20 °C~ +60 °C / -4 °F~ 140 °F

## Dimensions

Camera Head	W100 x H123 x D80 (mm) / W3.94 x H4.84 x D3.15 (inch)
CCU	W110 x H105 x D180 (mm) / W4.33 x H4.13 x D7.09 (inch)

## Weight

Camera Head	1.0 kg / 2.2 lbs. approx.
CCU	1.5 kg / 3.3 lbs. approx.

## Performance:

S/N Ratio	56dB
Modulation Depth	40% or more at 800TVL, 27.5MHz
Horizontal Resolution	1000TVL
Gain(dB)	-6, -3, 0, 3, 6, +9, +12, +18, +24, +30 (dB)
Gamma	OFF, 0.35, 0.40, 0.45
Electronic Shutter	1/100, 1/120, 1/250, 1/500, 1/1000, 1/2000 (Sec.)
Power Consumption	22W approx.
Output Signals	
Digital Video	2ch HD-SDI (75ohm, BNC connector/SMPTE292M)
Analog Video	R,G,B/Y,Pb/Pr Selectable (Multi-pin Connector)
Input Signal	
External Sync	HDTV: PS 1Vp-p, Sync 0.6Vp-p, ±6dB
(75Ω, BNC Connector)	SDTV: VBS 1Vp-p, BBS 0.3Vp-p



■ Rear View for CCU-F25i

## ■ HDL-F25i External Appearance (Unit: mm)

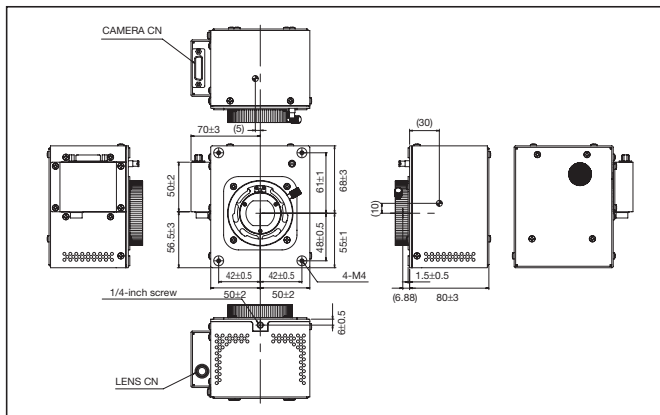

## ■ CCU-F25i External Appearance (Unit: mm)

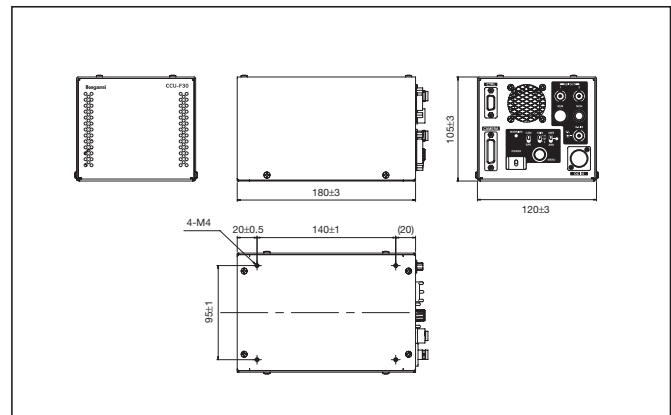

Design and specifications are subject to change without notice.

H163A094-H11 Printed in Japan

# Ikegami

## IKEGAMI ELECTRONICS (U.S.A.), INC.

■ URL <http://www.ikegami.com>

**HEADQUARTERS** 37 BROOK AVENUE, MAYWOOD, NJ 07607  
Phone:(201) 368-9171 Fax:(201) 569-1626

**WESTCOAST OFFICE** 2631 MANHATTAN BEACH BLVD., REDONDO BEACH, CA 90278  
Phone:(310) 297-1900 Fax:(310) 536-9550

**SOUTHWEST OFFICE** 773 BEARDEN WAXAHACHIE, TX 75167 Phone:(972) 869-2363 Fax:(972) 556-1057

**MIDWEST OFFICE** 747 CHURCH ROAD, UNIT C1, ELMHURST, IL 60126 Phone:(630) 834-9774 Fax:(630) 834-8689

**SOUTHEAST OFFICE** 5200 N.W. 33RD AVENUE, SUITE 111 FORT LAUDERDALE, FL 33309 Phone:(954) 735-2203 Fax: (954) 735-2227

